

CBCS Scheme

USN

--	--	--	--	--	--	--	--	--	--

15EE35

Third Semester B.E. Degree Examination, Dec.2016/Jan.2017 Digital System Design

Time: 3 hrs.

Max. Marks: 80

Note: Answer any FIVE full questions, choosing one full question from each module.

Module-1

- 1 a. Simplify the following Boolean function using K-map.
 $f(w, x, y, z) = \sum m(3, 7, 8, 10, 11, 12, 14, 15, 17, 19, 21, 23, 25, 27, 29, 31) + \sum d(2, 6, 26, 30)$. (08 Marks)
- b. Simplify the boolean expression using a 3-variable VEM with 'd' as MEV.
 $f(a, b, c, d) = \sum m(1, 3, 7, 11, 15) + \sum d(0, 2, 5)$. (08 Marks)

OR

- 2 a. Using Quine –McCluskey method, obtain a minimal sop expression of,
 $f(w, x, y, z) = \pi m(0, 4, 5, 9) \cdot d(1, 7, 13)$. (10 Marks)
- b. Find minimal sop expression using VEM with 'c' as MEV.
 $f(a, b, c, d) = \sum m(3, 4, 5, 7, 8, 11, 12, 13, 15)$. (06 Marks)

Module-2

- 3 a. Realize the following Boolean function using a 8:1 MUX with wyz as select inputs.
 $f(w, x, y, z) = \sum m(0, 1, 2, 5, 7, 8, 9, 12, 13)$. (06 Marks)
- b. Design a 1-bit comparator using 2-4 decoder giving three outputs, G, E and L. (04 Marks)
- c. Design a carry look ahead 4-bit parallel adder. Show that the time for addition is independent of the length of operands. (06 Marks)

OR

- 4 a. Implement a full subtractor using a 4:1 multiplexer. (06 Marks)
- b. Design a 4 to 16 decoder by cascading 2 to 4 decoders. (05 Marks)
- c. Explain a 4 to 2 line priority encoder with active high inputs and outputs using function table. (05 Marks)

Module-3

- 5 a. Analyse the application of SRFF as switch debouncer with waveforms. (03 Marks)
- b. Applying 4-bit shift register, design a 4-bit twisted ring counter. (05 Marks)
- c. Design a synchronous counter with counting sequence 3, 2, 5, 1, 0, 3 Using T,FF. (08 Marks)

OR

- 6 a. Explain race around condition. How is it eliminated? (04 Marks)
- b. Design and implement a divide by -10 asynchronous counter using T-FFs. (05 Marks)
- c. Design a synchronous counter to give a counting sequence 0, 2, 3, 1, 0 . . . using J,K FF. (07 Marks)

Important Note: 1. On completing your answers, compulsorily draw diagonal cross lines on the remaining blank pages.
2. Any revealing of identification, appeal to evaluator and/or equations written eg. 42+8 = 50, will be treated as malpractice.

Module-4

- 7 a. Construct a sequential logic circuit with single input and single output by obtaining the state and excitation table for the given state diagram using JK FF. (08 Marks)
- b. Analyze the following sequential circuit and obtain excitation, transition and state table. Also write the state diagram. (08 Marks)

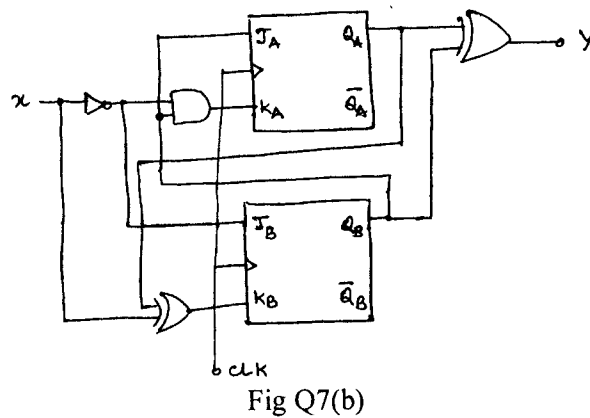
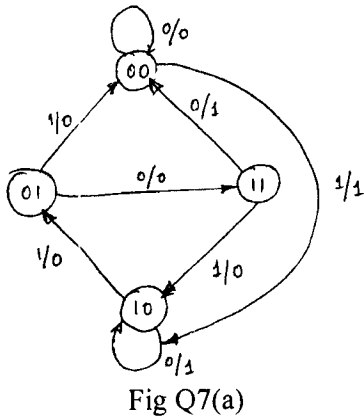

OR

- 8 a. By analyzing the sequential circuit obtain the equations for input a hence determine the excitation table, state table and state diagram. (06 Marks)
- b. Design the sequential logic circuit for a single input and single output system from the state diagram using JKFF. Analyze through state table and excitation table. (10 Marks)

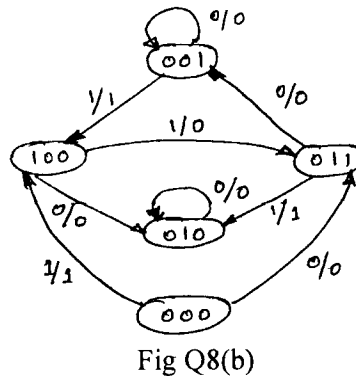
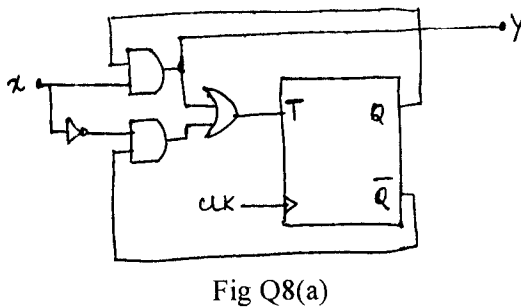

Module-5

- 9 a. Explain entity and architecture with reference to VHDL code of full adder circuit. (06 Marks)
- b. Write VHDL code using a process and case statement to implement 4:1 multiplexer. (04 Marks)
- c. Implement a T-FF with active low asynchronous inputs and clock input in VHDL. (06 Marks)

OR

- 10 a. Explain various data types available in VHDL. (06 Marks)
- b. Implement a single – bit comparator for all input combinations in VHDL. (04 Marks)
- c. Write VHDL code for edge triggered JKFF with active low asynchronous inputs. (06 Marks)
